

# High Performance Surface Peel Grinding With Electroplated CBN Wheels

Rausch, S., Marschalkowski, K., Biermann, D.<sup>1</sup>

<sup>1</sup>Institute of Machining Technology, ISF, Technische Universität Dortmund,  
44227 Dortmund, Germany  
Contact e-mail: rausch@isf.de

## **Abstract:**

*In this paper a novel grinding process for replacing conventional surface and creep feed grinding processes is presented. This grinding process is able to achieve high performances in hard machining with high flexibility and high surface finish. In this method a peel grinding process is conducted with a high workpiece velocity and a high depth of cut, using a conventional surface grinding machine and a shaped electroplated CBN wheel. To validate the efficiency of this process, experimental determination of the process forces and the surface roughness have been carried out. Applying the suggested method, high removal rates with a high surface finish can be achieved at the same time.*

## **Keywords:**

*High Performance Grinding, Surface Finish, Surface Peel Grinding*

## **1 INTRODUCTION**

High performance machining processes can be applied to increase the production rates. In particular, for the production of machine parts, molds and tools, while keeping the dimensional and shape accuracies of plane surfaces within the specifications. For this purpose, conventional grinding wheels are used in surface and creep feed grinding processes. The main characteristics of creep feed grinding processes are high achievable removal rates with a high depth of cut. On the other hand, the maximum workpiece velocity is strongly restricted due to thermomechanical loads occurring in the contact area between the grinding wheel and the workpiece. These loads can result in a thermal damage to the workpiece surface layer. Moreover, high cutting speeds are not approvable to be used, since they increase the thermal load likewise. On the contrary, surface grinding uses low depths of cut and therefore allows permitting high workpiece velocities. Thus, the resulting removal rates are low. To achieve high surface integrity, surface grinding processes have to be divided into three process steps: roughing, finishing and sparking out. Hence, the required machining time is increased. Additionally, it is recommended to use a width of cut of less than 5 mm to limit the evolving process forces and the resulting thermomechanical load [1]. In contrast, the so called high efficiency deep grinding (HEDG) is a high performance grinding process, which is designed to achieve high removal rates. The main characteristics of this process are high cutting speeds, high workpiece velocities and electroplated CBN grinding wheels [2]. Such tools offer high achievable specific removal rates, due to large chip space at the abrasive layer in combination with an excellent tool life. The produced surface integrity is strongly limited, however the surface roughness is high. This paper presents an alternative grinding process, which is high performance surface peel grinding (HP SPG), combining the potential of a high achievable removal rate with the possibility of generating a good surface finish at the same time. Therefore, a special kind of shaped electroplated CBN grinding wheel enables to conduct a combined roughing and finishing process.

## 2 HIGH PERFORMANCE SURFACE PEEL GRINDING (HP SPG)

Nowadays, peel grinding processes are used for machining external and internal surfaces of cylindrical workpieces [3, 4]. Hence, a shaped grinding wheel is separated into two zones. The material removal occurs in the conical zone and the surface finish in the cylindrical zone. The stock of the workpiece is removed in one pass by the axial feed motion of the grinding wheel along the workpiece rotational axis. Because of the small contact area between the grinding wheel and the workpiece, the main advantages of this grinding process are the combined roughing and finishing procedures, low process forces and increasing flexibility compared to plunge grinding. The application of electroplated grinding wheels at very high wheel speeds result in the highest achievable removal rates in internal hard machining, exceeding these of the hard turning processes. In comparison to hard turning at similar removal rates, the produced surface integrity shows even better results [5]. The surface finish can be realized by an alteration of the cylindrical finishing zone of the wheel via touch dressing. Thereby, the grain protrusion in this part of the wheel is leveled to a lower degree to achieve a good surface finish. On the other hand, the grain protrusion of the abrasive layer in the conical roughing zone is not altered. As a result, the performance of the wheel can be maintained, while the surface finish is improved.

In this research, the described peel grinding process is conducted on a conventional surface grinding machine using electroplated CBN wheels. As shown in **Figure 1**, the chip cross-sectional area  $A_D$  is divided into three functional zones for the material removal and a fourth one for the surface finishing.

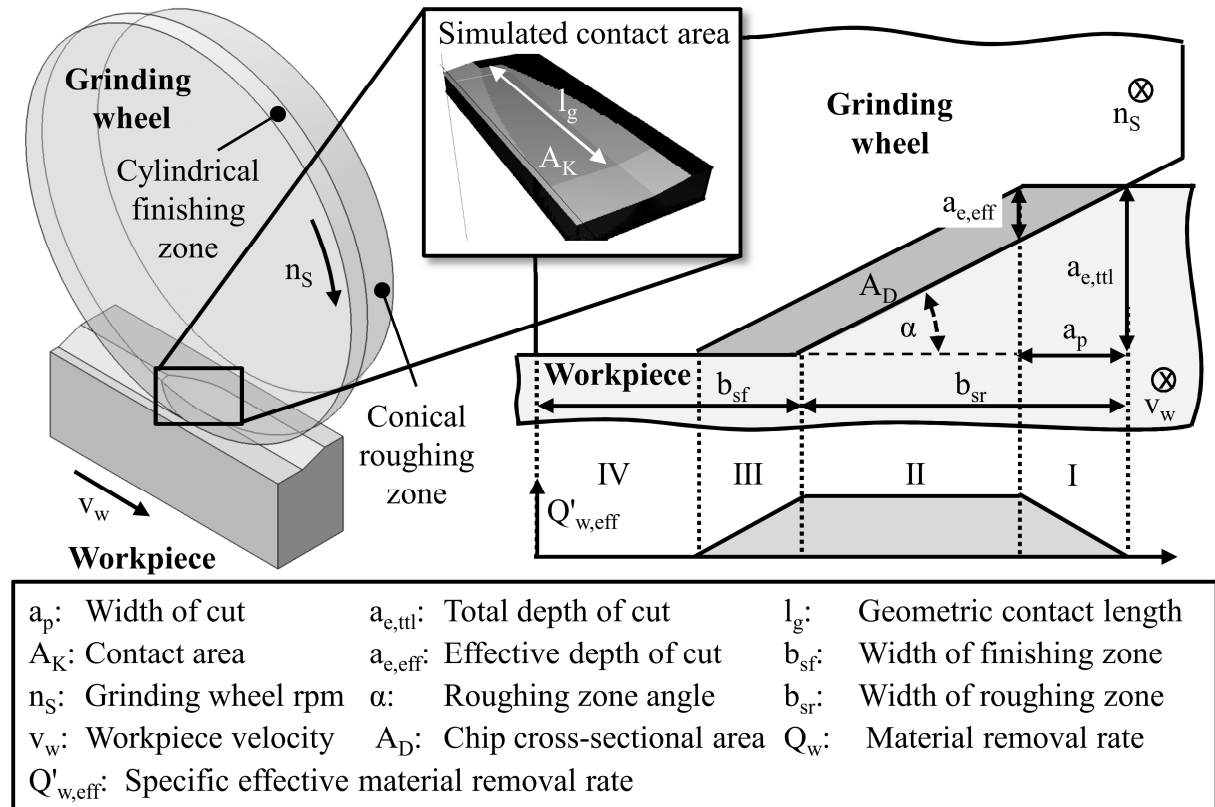

Figure 1: Process kinematics and contact conditions.

The section one of the chip cross-sectional area  $A_D$  shows a smooth run-in phase for the first contact between the grinding wheel and the workpiece. Due to reduced specific effective material removal rate, which can be calculated as

$$Q'_{w,eff} = a_{e,eff} \cdot v_w = a_p \cdot \tan(\alpha) \cdot v_w \quad (1)$$

in this section, the load on the grinding wheel remains low. Thus, the abrasive layer is prevented of getting damaged and a stable grinding process is provided while contacting the edge of the workpiece. The radial stock removal (total depth of cut  $a_{e,tll}$ ) is set once at the beginning of the process and it is machined in only one pass of the grinding wheel. In the second section of the chip cross-sectional area, the specific effective material removal rate  $Q'_{w,eff}$  remains constant, while in the third section  $Q'_{w,eff}$  descends to zero again. In the fourth section, no more chip formation takes place. The leveled abrasive grains of this area create a smooth workpiece surface. Firstly, the surface finish depends on the roughness of the abrasive layer of the grinding wheel. Secondly, it depends on the overlap factor  $U$ , which is represented by

$$U = \frac{b_{sf}}{a_p} \quad (2)$$

### 3 EXPERIMENTAL SETUP

A surface grinding machine Geibel & Hotz FS 635-Z CNC was used in addition with straight grinding oil for all experiments. To measure the occurring process forces a force dynamometer was placed on the machine table (**Figure 2**). The electroplated CBN grinding wheel applied for the experiments had a diameter  $d_s = 300$  mm, an angle  $\alpha = 10^\circ$  at the conical roughing zone and a width  $b_{sf} = 4$  mm at the cylindrical finishing zone. According to FEPA standard, the size of the abrasive grain material is B181. The resulting grit protrusion is about 40 % of the nominal grain size. The workpiece material was hardened steel 100Cr6 (1.2067) with a hardness of approx. 63 HRC.

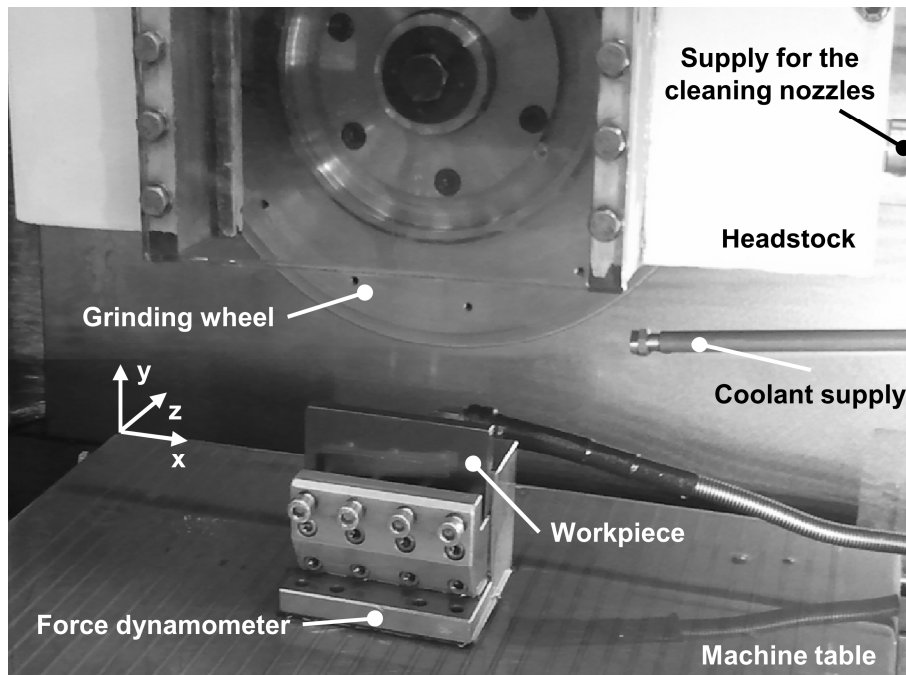

Figure 2: Experimental setup.

For the leveling of the grain protrusion in the finishing zone of the grinding wheel, touch dressing (TD) with a stationary dresser consisting of a mono-crystalline diamond was applied. To detect the first contact at the wheel grit in dressing, acoustic-emission was used. The sensor was mounted at the fixture of the dressing tool and the measurement signals were processed by a PC interface. For the preparation of the grinding wheel, the overall dressing infeed was increased successively in steps of  $a_{ed} = 1 \mu\text{m}$  with the constant traverse dressing feed velocity  $v_{fd} = 20 \text{ mm/min}$  and the dressing overlap factor  $U_d = 4.5$ . Only the cylindrical finishing zone is dressed, because dressing reduces the chip space volume and therefore the life of the grinding wheel. At the beginning of the experiments, the first grinding cycles were carried out to eliminate loose grains remaining from plating, until the process forces reached an almost constant level. Measuring the roughness of the produced surface, a mobile probe-tip measurement device (Hommel T1000) was used. For efficient coolant supply, a nozzle with the bore diameter  $\varnothing = 1.69 \text{ mm}$  for lubrication of the roughing and finishing zone between wheel and workpiece was applied. The grinding oil was supplied at the pressure  $p = 45 \text{ bar}$  with the volume flow rate  $\dot{V} \approx 14 \text{ l/min}$ . The resultant oil stream velocity lay within the applied grinding wheel velocities during the experiments. An additional oil stream for cleaning the roughing and finishing zone to flush the chips away from the wheel surface was supplied through four needle nozzles fixed at the headstock. The applied process parameters for the experiments were: cutting speed  $v_c = 80 \text{ m/min}$ , workpiece velocity  $v_w = 3\text{-}30 \text{ m/min}$ , total depth of cut  $a_{e,tll} = 0.2\text{-}0.7 \text{ mm}$  and width of cut  $a_p = 0.1\text{-}1 \text{ mm}$ .

#### 4 EXPERIMENTAL RESULTS AND DISCUSSION

As the first subject of this investigation, the influence of the workpiece velocity to the process forces was detected. Although, the roughness of the surface finish was neglected, because the grinding wheel was not dressed. Therefore, a basic set of parameters with a width of cut  $a_p = 0.1 \text{ mm}$  and a depth of cut  $a_{e,tll} = 0.2 \text{ mm}$  was used. The results of the experiments show the potential of the grinding process by using workpiece velocities  $v_w = 30 \text{ m/min}$ , without generating high process forces. Consequently, this maximum workpiece velocity is used for the following investigations to enlarge the material removal rate, which can be calculated as

$$Q_w = a_{e,tll} \cdot a_p \cdot v_w, \quad (3)$$

by increasing the total width of cut and the depth of cut, successively.

The maximum value of the total depth of cut  $a_{e,tll} = 0.7 \text{ mm}$  is limited by the width of the roughing zone  $b_{sr} = 4 \text{ mm}$  of the grinding wheel. The variation of  $a_{e,tll}$  was subject of the next set of grinding cycles, which are presented in **Figure 3**. The results of the experiments show a linear interdependence between the total depth of cut  $a_{e,tll}$  and the process forces  $F_a$ ,  $F_t$  and  $F_n$ . Though, the normal force rises up to  $F_n = 85 \text{ N}$  at a material removal rate  $Q_w = 35 \text{ mm}^3/\text{s}$  with the total depth of cut  $a_{e,tll} = 0.7 \text{ mm}$ . However, the maximum tangential force is lower than  $F_t = 20 \text{ N}$  and the maximum axial force is below  $F_a = 10 \text{ N}$ . Although, the grinding wheel was not dressed, the values of roughness  $R_z$  and  $R_{max}$  were constant with the total depth of cut.

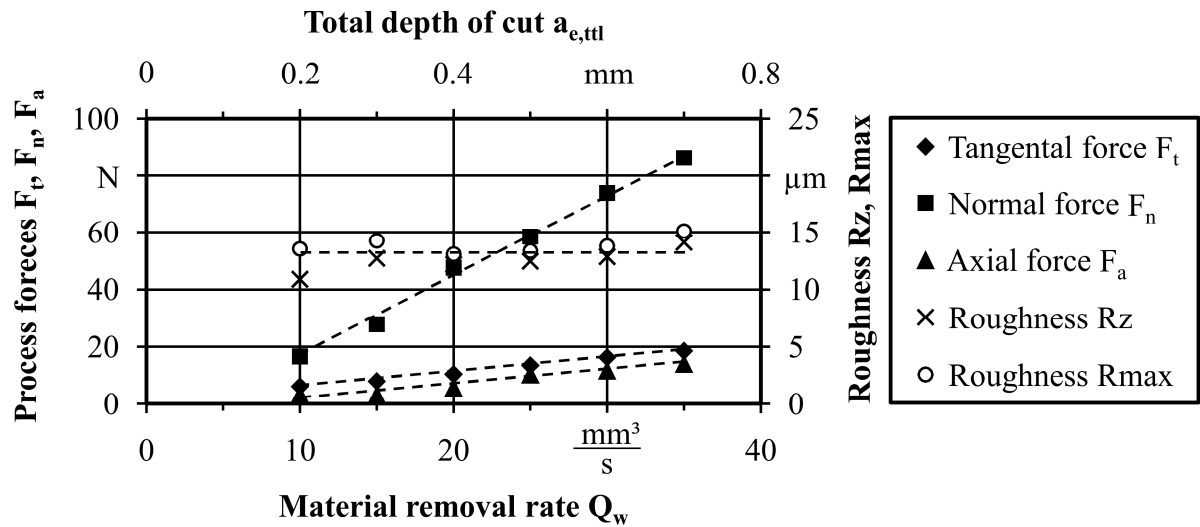

<b>Workpiece:</b>	100Cr6, 63±1 HRC	<b>Grinding:</b>	
<b>Grinding wheel:</b>	Plated B181, $\alpha = 10^\circ$ , $b_{sf} = 4$ mm	$a_{e,tll} = 0.2-0.7$ mm, $a_p = 0.1$ mm	
<b>Coolant:</b>	Grinding oil, $v(40^\circ C) = 10$ mm <sup>2</sup> /s	$v_s = 80$ m/s, $v_w = 30$ m/min	
<b>Dressing:</b>	$a_{ed,tll} = 0$ $\mu m$ , not dressed		

Figure 3: Process forces and roughness in dependence of the width of cut.

As shown in **Figure 4**, by increasing the width of cut from  $a_p = 0.1$  mm up to  $a_p = 1$  mm, the material removal rate raises from  $Q_w = 10$  mm<sup>3</sup>/s to  $Q_w = 100$  mm<sup>3</sup>/s according to equation (3). As it can be recognized, the process forces are climbing proportionally to the width of cut. By increasing the width of cut, the overlap factor  $U$  decreases and the values of the resulting surface roughness are higher. The maximum value of the surface roughness is reached at the width of cut  $a_p = 0.5$  mm. Higher widths of cut do not increase the roughness anymore.

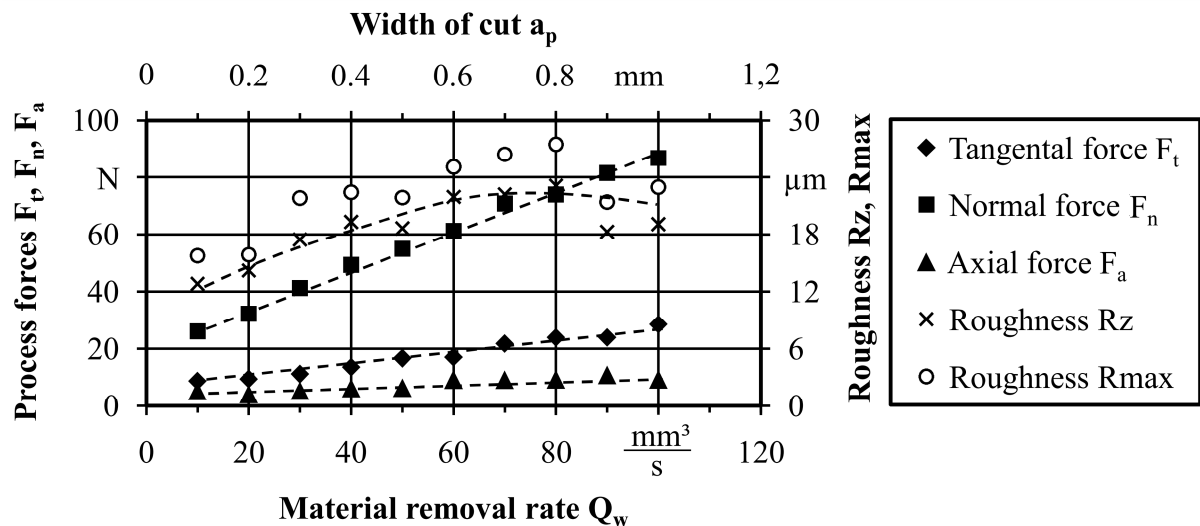

<b>Workpiece:</b>	100Cr6, 63±1 HRC	<b>Grinding:</b>	
<b>Grinding wheel:</b>	Plated B181, $\alpha = 10^\circ$ , $b_{sf} = 4$ mm	$a_{e,tll} = 0.2$ mm, $a_p = 0.1-1$ mm	
<b>Coolant:</b>	Grinding oil, $v(40^\circ C) = 10$ mm <sup>2</sup> /s	$v_s = 80$ m/s, $v_w = 30$ m/min	
<b>Dressing:</b>	$a_{ed,tll} = 0$ $\mu m$ , not dressed		

Figure 4: Process forces and roughness in dependence of the total depth of cut.

To achieve the required surface finish, it is necessary to dress the grinding wheel by reducing the grain protrusion of the most protruding grits of the electroplated abrasive layer. Therefore, the grinding wheel was dressed successively in steps of  $a_{ed} = 1 \mu\text{m}$  with the constant traverse dressing feed velocity  $v_{fd} = 20 \text{ mm/min}$  and the overlap dressing rate  $U_{ed} = 4.5$ . This procedure causes a flattening of the touch dressed grains due to very small dressing infeed. While the total dressing infeed is increased, the normal force slightly rises to the constant value of  $F_n = 80 \text{ N}$  at  $a_{ed,tll} = 15 \mu\text{m}$  (see **Figure 5**). The reduction of the grain protrusion in the finishing zone does not have an effect to the cutting ability of the roughing zone of the grinding wheel. Therefore, the tangential force  $F_t = 18 \text{ N}$  remains constant at the material removal rate  $Q_w = 50 \text{ mm}^3/\text{s}$ . As a result of dressing, the measured values of the surface roughness decrease to  $R_z \approx 3 \mu\text{m}$  and  $R_{max} \approx 4 \mu\text{m}$  at the total dressing infeed  $a_{ed,tll} = 20 \mu\text{m}$ .

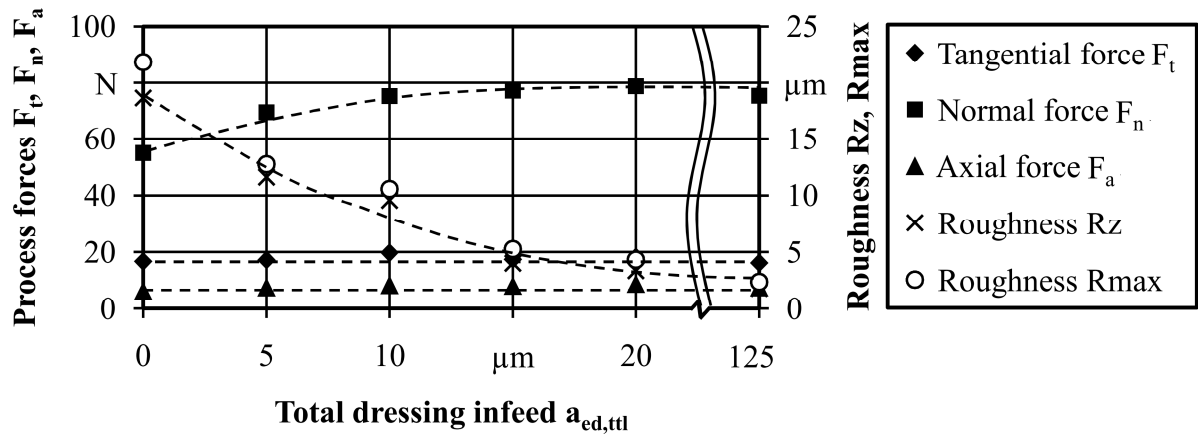

<b>Workpiece:</b>	100Cr6, 63±1 HRC	<b>Grinding:</b>	
<b>Grinding wheel:</b>	Plated B181, $\alpha = 10^\circ$ , $b_{sf} = 4 \text{ mm}$	$a_p = 0.5 \text{ mm}$ , $a_{e,tll} = 0.2 \text{ mm}$	
<b>Coolant:</b>	Grinding oil, $v(40^\circ\text{C}) = 10 \text{ mm}^2/\text{s}$	$v_w = 30 \text{ m/min}$ , $v_s = 80 \text{ m/s}$	
<b>Dressing:</b>	$a_{ed} = 1 \mu\text{m}$ , $v_{fd} = 20 \text{ mm/min}$	$Q_w = 50 \text{ mm}^3/\text{s}$ , $Q'_w = 44 \text{ mm}^3/\text{mm} \cdot \text{s}$	

Figure 5: Process forces and roughness in dependence of the total dressing infeed.

To evaluate the influence of higher values of the total dressing infeed and to determine the limit of the achievable values of the surface roughness in the next step, the dressing infeed  $a_{ed} = 100 \mu\text{m}$  was applied. While each values of  $R_z$  and  $R_{max}$  reach a minimum of  $2 \mu\text{m}$ , the normal force  $F_n$  is not influenced anymore and it remains constant despite the increased total dressing infeed. As a consequence, using HP SPG the surface roughness is effectively reduced to a much lower value via touch dressing, without having a negative effect on the tool life or the cutting ability of the grinding wheel. The achievable minimum value of the surface roughness is depending on the grinding parameters and the active grain density as well as on the grain flat area. The two depressions can be changed according to the dressing parameters.

Considering the specific grinding energy, the process efficiency can be evaluated according to the changes during the chip formation. The specific grinding energy  $e_c$  describes the energy needed to remove  $1 \text{ mm}^3$  of material from the workpiece and it can be calculated as

$$e_c = \frac{F_t \cdot v_c}{Q_w} = \frac{F'_t \cdot v'_c}{Q'_w} \quad (4)$$

By increasing the material removal rate  $Q'_w$ , the specific grinding energy decreases and the process becomes more efficient. The thermal load on the workpiece surface can be approximated by the area specific grinding energy  $E''_c$ , which is defined as

$$E''_c = \frac{F'_t \cdot v_c}{v_w} = \frac{F_t \cdot v_c}{b_{sr} \cdot v_w}. \quad (5)$$

The area specific grinding energy  $E''_c$  displays the quantity of energy flux into a surface element of  $1 \text{ mm}^2$  at the workpiece surface. The results of the energy balance are presented in **Figure 6**. While raising the specific material removal rate  $Q'_w$  by increasing the width of cut  $a_p$  or the workpiece velocity  $v_w$ , the specific grinding energy  $e_c$  decreases, according to the reduction of the elastic plastic deformation in chip formation due to higher undeformed chip thickness. Regarding the contact area specific grinding energy  $E''_c$ , the values are raising proportional to the width of cut  $a_p$  because of the increasing contact time between the grinding wheel and the workpiece. Consequently,  $E''_c$  is declining with the workpiece velocity  $v_w$  due to reduced contact time  $t_k$  which can be calculated as

$$t_k = \frac{l_g}{v_w} = \frac{\sqrt{a_{e,eff} \cdot d_{eq}}}{v_w}. \quad (6)$$

So, it is recommendable to use high workpiece velocities to increase the energy efficiency in grinding and to reduce the thermal load on the workpiece surface. The influence of the grinding energy on the surface integrity is subject of current research.

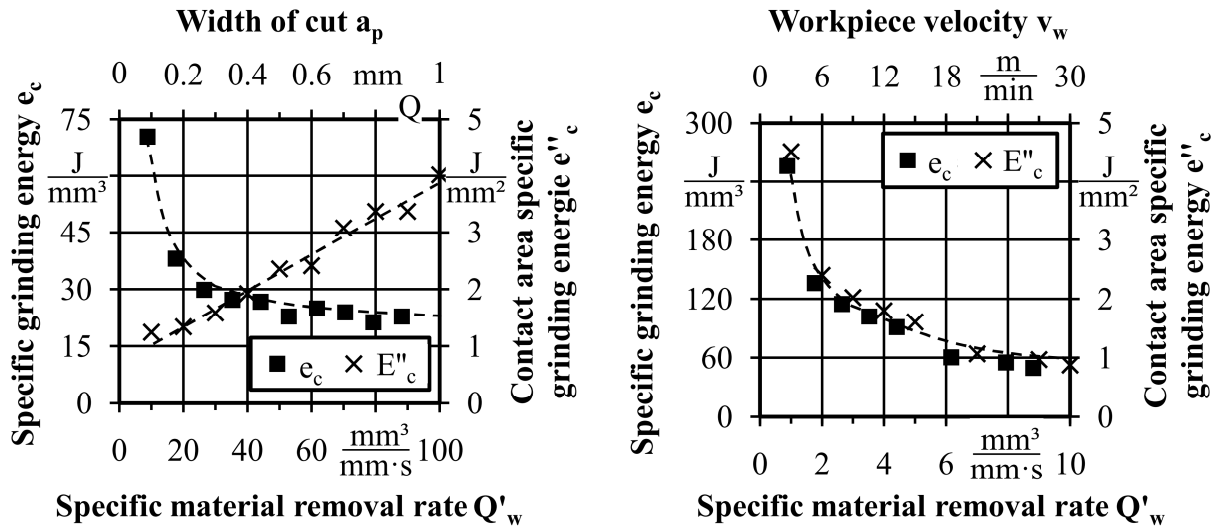

<b>Workpiece:</b>	100Cr6, 63±1 HRC	<b>Grinding:</b>	
<b>Grinding wheel:</b>	Plated B181, $\alpha = 10^\circ$ , $b_{sf} = 4 \text{ mm}$	$a_{e,tll} = 0.2 \text{ mm}$ , $a_p = 0.1-1 \text{ mm}$	
<b>Coolant:</b>	Grinding oil, $v(40^\circ\text{C}) = 10 \text{ mm}^2/\text{s}$	$v_s = 80 \text{ m/s}$ , $v_w = 3-30 \text{ m/min}$	
<b>Dressing:</b>	$a_{ed,tll} = 0 \text{ }\mu\text{m}$ , not dressed		

Figure 6: Energy balance in HP SPG in dependence of the width of cut and the workpiece velocity.

## 5 CONCLUSION

The presented grinding process of high performance surface peel grinding (HP SPG) permits a significant enhancement of the material removal rate  $Q_w$  and the roughness of the surface finish at the same time. Therefore, an electroplated CBN grinding wheel, consisting of a conical roughness zone and a cylindrical finishing zone, is used. The surface finish can be improved by an alteration of the cylindrical finishing zone of the wheel via touch dressing without having an effect on the tool life and the cutting ability of the grinding wheel. Thereby, minimal values of the surface roughness  $R_z \approx 3 \mu\text{m}$  and  $R_{\text{max}} \approx 4 \mu\text{m}$  have been reached. In addition to high workpiece velocities up to  $v_w = 30 \text{ m/min}$  for standard surface grinding machines, a high total depth of cut up to  $a_{e,\text{ttl}} = 0.7 \text{ mm}$  has been successfully tested. The process enables a wide variety of grinding workpieces surfaces, e.g. for the high performance production of machine parts, molds and tools.

## REFERENCES

- [1] Ferlemann, F., 1992, Schleifen mit höchsten Schnittgeschwindigkeiten, dissertation, RWTH Aachen
- [2] Tawakoli, T., 1989, Technologie des Hochleistungs-Flachschleifens, dissertation, Universität Bremen
- [3] Aronson, R., 2006, The Powerful Potential of Peel Grinding, Manufacturing Engineering, Vol. 136, No. 2
- [4] Finke, M., 2003, Untersuchungen zur Auslegung und Optimierung des Innenrund-Längsschleifens von Futterteilen, dissertation, Technische Universität Dortmund
- [5] Marschalkowski, K., Biermann, D., Weinert, K., 2010, On the Characteristics of High-Performance Internal Traverse Grinding Using Electroplated CBN Wheels, Proceedings of the 4th CIRP International Conference on High Performance Cutting (CIRP HPC 2010), Gifu, Japan, Vol. 1

